



DE5817-

English

DL-125C, DL-125CA

Programmable 2-Channel Speech Dialer



Visonic

Installation Instructions

1. INTRODUCTION

1.1 General description

The DL-125C and DL-125CA are automatic programmable speech dialer designed for verbal reporting of events.

Features

- 2 alarm inputs (Z-1 & Z-2).
- When each input is triggered, a specific prerecorded verbal message is reported to 4 remote telephones.
- When an event occurs, it can be reported to different 4 telephones or (if both inputs are connected in parallel) to different 8 telephones.
- The target telephone numbers may be frequently reprogrammed by the user.
- If the telephone line is disconnected, the two output terminals LF (solid state switch) are shorted or open (programmable). These terminals can be used to send a signal to the alarm system for telephone line failure indication.
- The alarm logic of each input can be programmed by the installer (activation when alarm input is "open" or "closed").
- Selectable Pulse or DTMF dialing method.
- Certain functions can be performed in response to DTMF control commands received from remote telephones.
- Whenever a message is acknowledged by the called party, a highly sensitive microphone is activated, to allow the called party to listen and hear sounds in the installation site.
- The "listening-in" period is limited in time, but the called party can send a specific DTMF command to prolong it.
- Programmed data is retained in an EEPROM, unaffected by power failures.
- A communication session with the first / second group of telephones is initiated by triggering alarm inputs Z-1 / Z-2, or by pressing AL-1 / AL-2 on the front panel, respectively.

Dialer Types

Type	Dialing Can be Stopped by:	
	Pressing STOP button	Manual or Automatic Power Disconnection
DL-125C	YES (*)	YES
DL-125CA	NO (**)	YES

* Provided that momentary alarm contacts are used.

** This feature is sometimes required by regulatory authorities.

1.2 Applications

- Upgrading alarm control panels that do not have a dialer. Two different events can be reported to remote telephones.
- Stand-alone 2-input 24-hour alarm system, triggered directly by a smoke/shock detectors or a panic button (loop response time 200 ms).
- Looking after infants or old, sick and disabled people. The dialer delivers a distress message and then allows the called party to "listen in".
- Supervising unattended technical devices or processes, with verbal reporting of equipment failures or process anomalies.
- Transmitting numeric reports to numeric pagers or voice messages to voice pagers.

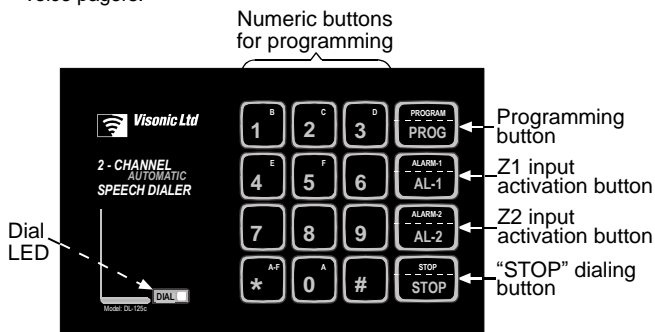

Figure 1. Front Panel

1.3 Message Structure

The overall length of the speech message that can be recorded is limited to 20 seconds (see par. 5.4). Within this limit, the message can be composed of two pre-recorded segments:

- The identification segment, common to both alarm inputs. This segment usually identifies the user or the protected premises.
- The alarm type segment, associated with a specific alarm input. This segment is used to describe the type of event reported ("fire", "intrusion", "panic", etc.).

A transmission initiated by a specific event (one of the two alarms) is composed of the **identification** segment and one of two **alarm type** segments. The order of transmission of the two segments can be selected. For instance, you can select: "The Smith residence, 25 Scarecrow Drive – Fire Alarm", or you can select: "Fire Alarm – the Smith residence, 25 Scarecrow Drive".

1.4 Communication Routine

Note: In this section, location numbers identify "memory cells" that retain programmed parameters (see Para. 5.8).

Once triggered into action, the dialer introduces a programmed pre-dialing pause (see Location 14 in Para. 5.8). Then it disconnects the local telephone set and engages the telephone line. The DIAL LED lights and the process continues as follows:

- The dialer starts dialing if uninterrupted tone is detected for 2 seconds (see C below). If 5 seconds elapse with no dial tone - the dialer disengages the line, waits 5 seconds and tries again. If another 5 seconds go by without dial tone, the dialing procedure starts anyway (see B below).
- The dialer checks whether a letter is programmed as a prefix to the first telephone number. Letter prefixes impose an additional delay before dialing (see Para. 5.2). The dialer introduces the required delay (if any) and then starts dialing.
- The dialer dials the programmed number. During dialing, the LED either remains lighted (DTMF dialing) or flashes (pulse dialing), depending on the dialing method selected. After dialing, the dialer pauses for 5 seconds and transmits the message prepared for the called party associated with the input that had been triggered.
- The dialer now waits 3 seconds for the called party to acknowledge (the acknowledgement signal is DTMF "1").
- Upon receiving the acknowledgement signal, the dialer removes the presently contacted telephone from its task list for the current event. If the "listen in" function is permitted (see Location 10 in Para. 5.8) it will continue as in Paragraphs F and G below. If not, the dialer will go "on hook" and proceed to dial the next number.

Note: Without an acknowledgement, the message will be repeated until the maximum number of message repeats is reached (see Location 20 in Para. 5.8). The dialer will call the remaining numbers and will then repeatedly retry the number that didn't acknowledge, until the maximum number of dialing attempts is reached (see Locations 12 and 13).

- After acknowledgement, the dialer enables the "listen in" function for a preprogrammed period.
- At the end of the listen-in period, a short beep sounds. If the called party keys "1" within 10 seconds, a new listen-in period begins. Otherwise, the dialer will go "on hook". The listen-in period may be prolonged as many times as necessary or terminated at any time by keying "9" twice in succession.
- Upon conclusion of the communication session with the first telephone, the procedure in A through G above will be repeated for all remaining telephone numbers in the relevant group (provided that the "non-backup mode" has been selected in Location 24).

Note: Location 24 allows selection of "backup" or "non-backup" mode. In the backup mode, acknowledgement from one telephone is enough to close the event. In the "non-backup" mode, acknowledgement must be obtained from all telephones in the group.

- Once the entire communication cycle is concluded, the dialer disengages the line and reverts to the standby state. If you are using the **DL-125C**, the communication routine may be aborted at any time by pressing the STOP button on the keypad (provided that the input is no longer in alarm). If you are using the **DL-125CA**, the only way to stop the dialer is to disconnect the power, because the STOP button is disabled.

2. SPECIFICATIONS

Input Circuits: Two N.O. or N.C. inputs (programmable)

LF Alarm Output Type: Solid-state relay, N.O. or N.C. (programmable), up to 100 mA / 30 V, ~30 Ω internal resistance. (note: this output is comprised of two terminals that have no polarity)

Warning beeps in the event of a telephone line failure: An internal buzzer, housed within the dialer, sounds beeps (if the buzzer jumper was not previously moved to the "OFF" state - see Figure 2.2).

WARNING! If the buzzer jumper is in the "Buzzer ON" state (see Chapter 3), do not program the LF starting points to the "Closed Contact" state. Otherwise, the buzzer will beep when the telephone line is in working order.

Alarm Logic: Alarm upon circuit closure or upon circuit opening (programmable)

Dialing Method: Pulse or DTMF (programmable)

Tel. Line Impedance: 600Ω, or customized to meet local requirements in country of use.

Reporting Destinations: Two groups of telephone numbers, 4 telephones in each group. Reporting to one pager requires the memory space dedicated to two telephone numbers.

Tel No. Length: 20 digits maximum.

Speech Message Duration: 20 seconds max.

No. of Dialing Attempts: 1 – 15 (programmable)

No. of Message Repeats: 1 – 255 (programmable)

Acknowledge Pause between Message Repeats: 3 seconds

Power Supply: 12-24 VDC (nominal)

Maximum Current Drain: 20 mA (standby), 105 mA (operation)

Operating Temperatures: 0°C to 50°C (32°F to 122°F)

Size: 150 x 105 x 35 mm (5-7/8 x 4-1/8 x 1-3/8 in.)

Weight: 235 g (8.3 oz)

Standards: Compatible with RTTE requirements - Directive 1999/5/EC of the European Parliament and of the Council of 9 March 1999. EN50131 Grade 2 Class II.

3. MOUNTING

The dialer may be installed as a stand-alone unit or within the housing of a host system such as an alarm control panel.

Removing the Front Panel

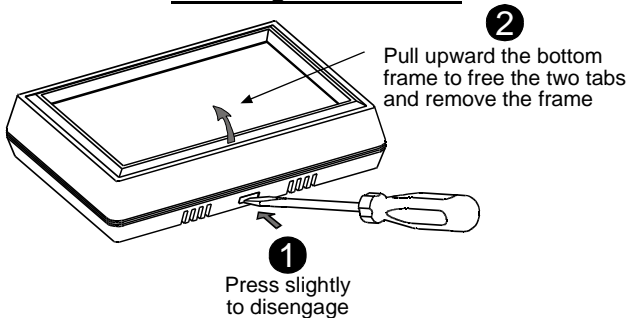

Separating the Module from the Base

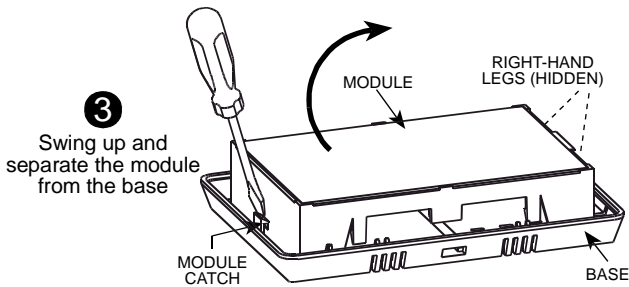

Securing the Base to a Wall or Host System Cabinet

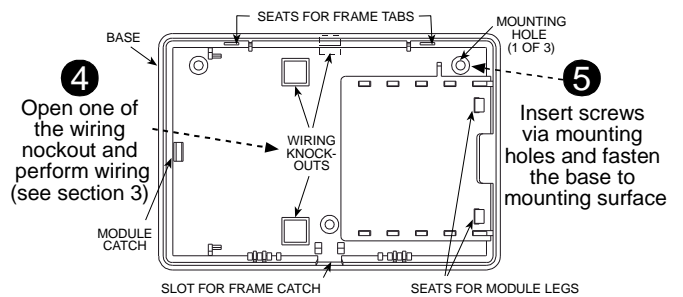

Remounting the Module

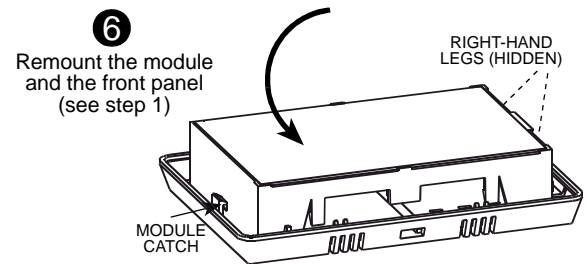

Figure 2.1. Mounting

Disabling the internal buzzer that alerts on telephone line failure:

The dialer is shipped by the manufacturer with the buzzer jumper in the "Buzzer ON" state. If you do not want warning beeps to sound, in the event of a fault in the telephone line, move the buzzer's jumper to the "Buzzer OFF" state. For this purpose you must access the dialer's PCB (by performing steps 1 through 3 in Figure 2.1) and then move the dialer's jumper to the "Buzzer OFF" state - see Figure 2.2.

WARNING! If the buzzer jumper is in the "Buzzer ON" state, do not program the LF starting points (see Appendix A) to the "Closed Contact" state. Otherwise, the buzzer will beep when the telephone line is in working order.

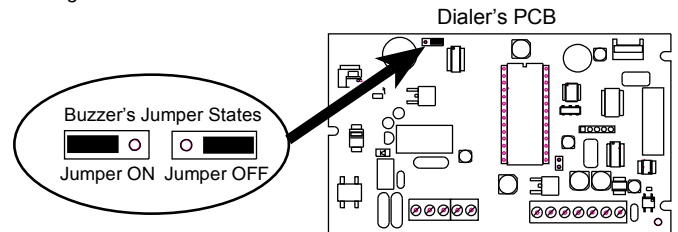

Figure 2.2. Moving Buzzer's Jumper to ON / OFF State

4. WIRING

The dialer can be powered by constant power supply or by a switched power supply. When the dialer receives switched power from an alarm system, it will be disabled upon stopping the alarm, since the alarm relay cuts off the power. This type of wiring is ideal when the dialer is mounted in a locked box that prevents access to the STOP pushbutton.

Note: Both Z-1 and Z-2 inputs can be programmed as N.O. (normally open) or N.C. (normally closed) inputs (see Locations 22 & 23 in Para. 5.8). With N.O. inputs selected, a short circuit across the relevant input will activate the dialer.

With N.C. inputs selected, an open circuit across the relevant input will activate the dialer.

Use 15 AWG or larger conductor to connect the EARTH terminal to the nearest electrical ground, preferably a ground rod.

Failure to earth the unit compromises safety!

The phone connected to the SET terminals will be automatically disconnected from the line whenever the dialer goes into action.

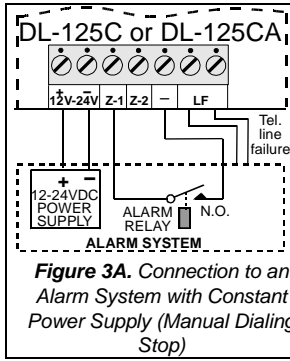

Figure 3A. Connection to an Alarm System with Constant Power Supply (Manual Dialing Stop)

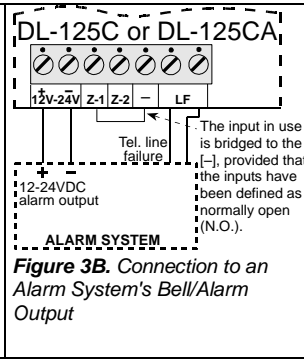

Figure 3B. Connection to an Alarm System's Bell/Alarm Output

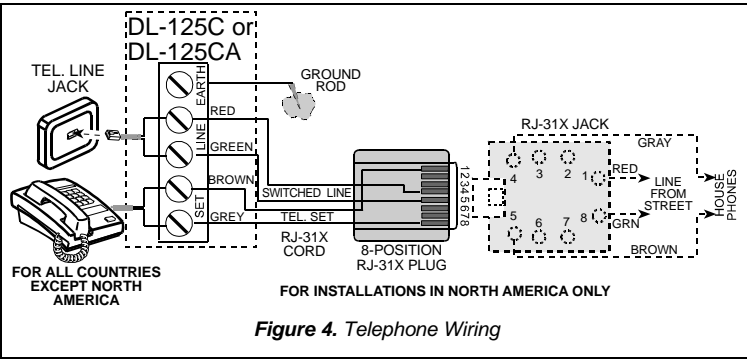

Figure 4. Telephone Wiring

5. PROGRAMMING

5.1 Programming Fundamentals

The dialer employs a non-volatile EEPROM, that stores programmed data and keeps it intact even during power failures. Programming is carried out from the keypad by entering the desired variables or by setting logic flags. Every variable is programmed into a specific location in the memory, and each location is identified by a LOCATION NUMBER. A set of default parameters is programmed at the factory and saved in the EEPROM, but you may change these at will (see Para. 5.8). The programming format consists of the following successive entries:

[PROG] <LOC> [#] <VAL> [#]

[PROG] and [#] are keys provided on the keypad. [PROG] starts the programming sequence and [#] confirms the preceding entry. <LOC> is the location number. A leading zero may be ignored, so Location 06 may be entered as a single digit - <6>. <VAL> is the value or code entered into the selected location.

Refer to the PROGRAMMING CHART (Para. 5.8) for a full list of locations, permissible entries and function details.

Caution! If an invalid parameter is entered at any stage, the LED will flash rapidly for 2 seconds and programming will be aborted.

You will sometimes have to key the hexadecimal digits B, C, D and E (see Para. 5.2 and 5.6). These digits are marked on certain keys (see Figure 1). To start the hexadecimal mode, press [*]. The DIAL LED near the keyboard will flash rapidly. Next, press the key with the desired letter. The keypad will automatically revert to its normal numerical function, and the LED will stop flashing. Press [*] again if you wish to key another letter. Voice recording instructions are given in Paragraph 5.4.

5.2 Entering Telephone Numbers

Telephone numbers are entered in locations 1 through 4 (1st group) and 5 through 8 (2nd group). The programming format is:

[PROG] <LOC> [#] <NUM.> [#]

- A. Enter the programming mode by pressing the PROG key. The DIAL LED should light steadily.
- B. Select the location for the telephone number you wish to program by keying its location (LOC) number. The DIAL LED should flash once for each keystroke.
- C. Press [#] to confirm the location number. The LED should flash twice.
- D. Key the telephone number (NUM), digit by digit. The DIAL LED should flash once for each digit. There is a 20-digit limit, including inter-digit pauses (see following note).

Note: To program pauses between dialed digits, as sometimes required when PABX systems are used, the following entries are available:

Code Letter	Key Strokes	Resultant Function
B	[*][1]	wait 5 seconds or wait for dial tone, whichever comes first, and continue dialing.
C	[*][2]	wait 10 seconds and continue dialing.
D	[*][3]	wait 5 seconds for dial tone and disengage the line if none is received.

After pressing [*], the LED indicator flashes until a letter key is pressed.

- E. Having entered the last digit, finish off by keying [#]. The DIAL LED indicator will extinguish.
- F. To program another telephone number, repeat the procedure outlined in steps A to E above.

5.3 Deleting Telephone Numbers

A telephone number location will "blank out" if you go through the programming process as in B above but skip the telephone number. The deleting format is therefore:

[PROG] <LOC> [#] [#]

Note: The number already programmed into any location between 1 and 8 may be verified by using the following format:

[PROG] <LOC> [*]

This initiates a communication session with the particular telephone, and provides a chance to verify correctness of the programmed phone number.

5.4 Recording and Erasing

A. Recording Procedure

You must record at least the identification message and one of the alarm messages (AL-1 or AL-2). You cannot record only the identification message. Recording should be in the following order:

Message Segment	Actions Required	Response
Identification (up to 14.5 seconds)	1. Press [#]	LED flashes once.
	2. Within 2 sec., press and hold down [AL-1]+[AL-2] and talk	LED lights steadily & recording starts.
	3. Release [AL-1]+ [AL-2] and press [#] to save the message	Recording ends & LED extinguishes
AL-1 (up to 2.5 seconds)	1. Press [#]	LED flashes once.
	2. Within 2 sec., press and hold down [AL-1] and talk	LED lights steadily & recording starts.
	3. Release [AL-1] and press [#] to save the message	Recording ends & LED extinguishes
AL-2 (up to 2 seconds)	As for AL-1, but press AL-2 instead	As for AL-1

Please note: If recording time is exceeded, the DIAL LED will flash rapidly

B. Erasing Recorded Messages

Press [#] - the DIAL LED flashes once. Within 2 seconds, press [AL-1]+[AL-2], or [AL-1] or [AL-2] depending on which message you wish to erase. Then press [#] again immediately. The previous message will be erased.

5.5 Defining LF Output as N.O or N.C

The LF (tel. line failure) output terminals can be programmed as N.O (Normally open, default state) or N.C. (Normally closed). The programming format is:

[PROG] <16> [#] <CODE> [#]

"16" is the memory location number. "CODE" is the code entered into location 16; "0" for N.O., "1" for N.C.

5.6 Dealing with Pagers

You may program the dialer to dial a pager's phone number and send a numeric or verbal message. Communication with a single pager requires two consecutive locations in the dialer memory - one for the pager's phone number and another for the numeric data sent to the pager. Since each dialer input has 4 memory locations for phone numbers, each input can report to one pager and 2 regular telephones or just two pagers.

If the pager's phone number is entered into Location No. 1, the numeric message for that pager must be entered into the next location (No. 2). If the pager's phone number is entered into Location No. 2, the numeric message for that pager must be entered into the next location (No. 3).

Important! Location No. 4 (the last location in the first group) and No. 8 (the last location in the second group) can't be used for pager phone numbers - in both cases there is no "next location" with memory space for the message.

In the backup mode (see Para. 1.4H), it is advisable to use Locations 1 & 2 or 5 & 6 for pager data and the remaining locations for telephone numbers. The dialer will therefore call the pager first and, since the pager doesn't acknowledge, at least one of the telephone numbers will also be called.

Numeric pagers accept both the subscriber ID (PIN number) and a numeric message which is registered and forwarded to the subscriber. Voice pagers accept the subscriber ID (PIN number), record a verbal message and relay it to the subscriber.

Note: Some pagers have a special phone number assigned to each specific subscriber. This type of pager does not require a PIN number. Some pagers require an asterisk (*) as a separator between the subscriber code and the message. Other pagers require the pound symbol (#). Correct programming is totally dependent on your ability to make the dialer "talk" to the paging company's computer in a language it "understands" (Fig. 5).

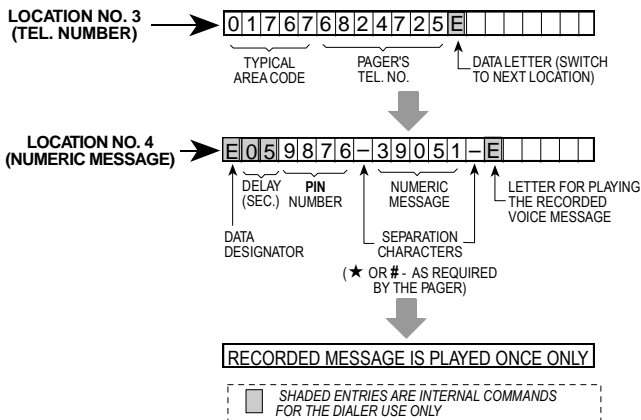

Figure 5. Typical Data Arrangement in Memory

Contact the paging company for specific interface details (PIN or no PIN, separating characters required etc.).

Figure 5 depicts a typical arrangement of data in the dialer memory for reporting an event to a pager. In this example, the phone number is entered into memory location No. 3, and the numeric message is entered into the memory location No. 4.

A hexadecimal E at the end of the phone number tells the dialer move to the next memory location and send the data stored in it.

A hexadecimal E at the beginning of a memory location identifies the contents of this location as pager data. A hexadecimal E after the data serves as a cue for playing the voice message.

To program communication with a pager:

- Reserve 2 consecutive memory locations in the same group of four.
- Suppose the first location you chose is No. 3. Select it by keying [PROG], <3>, [#].
- Suppose the area code is 01767 and the telephone number is 682-4725. Key in the data as exemplified in Figure 6.
- Press [#] to confirm the data just entered.
- Select the next memory location by keying: [PROG], <4>, [#]

ENTRIES INTO LOCATION 3 (LEFT TO RIGHT)

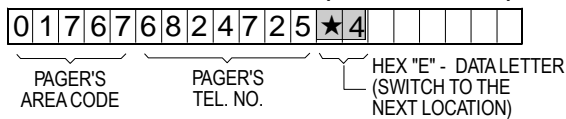

[*][4] produces a Hexadecimal E, a cue for data in the next memory location.

Figure 6. Programming the Pager's 1st Location

- Suppose the target pager requires a 5 second interval between the end of dialing and the beginning of the message. Also suppose that the PIN number is 9876 and the message is 39051. Key the data as shown in Fig.7.

ENTRIES INTO LOCATION 4 (LEFT TO RIGHT)

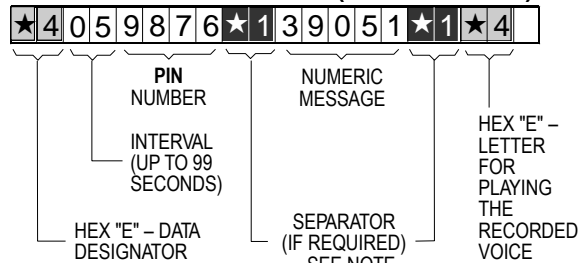

Figure 7. Programming the Pager's 2nd Location

Notes: If the required separator is # - key [*][1]

If the required separator is * - key [*][2].

In case of a pager that does not forward voice messages - skip the last [*][4].

If you need a 5-second delay anywhere within the message, key [*][3].

- Press [#] to confirm the data just entered.

5.7. Programming Summary

The dialer can be programmed equally well in the installer's office or at the installation site. Follow the PROGRAMMING CHART (Para. 5.8) row by row, and enter the appropriate variables. The code options are explained in the second column, and the full programming sequence for each variable is given in the fourth column. Each programming step is enclosed in square brackets, and may include more than one keystroke. The fifth column shows the default values, and the last column (Prog) is left blank for you to fill in your own programmed values.

Note: If no key is pressed for 30 seconds, programming will be aborted and the selected location will revert to the previously saved value.

To quit programming at any stage, press the [STOP] key.

5.8 Programming Chart

Loc. No.	Description of Parameters & Code Options	Entry Limits	Programming Format	Factory Default	Prog. Record
1	1st telephone number associated with input Z-1	20 digits	[PR] [1] [#] [Num] [#]**	None	
2	2nd telephone number associated with input Z-1	20 digits	[PR] [2] [#] [Num] [#]**	None	
3	3rd telephone number associated with input Z-1	20 digits	[PR] [3] [#] [Num] [#]**	None	
4	4th telephone number associated with input Z-1	20 digits	[PR] [4] [#] [Num] [#]**	None	
5	1st telephone number associated with input Z-2	20 digits	[PR] [5] [#] [Num] [#]**	None	
6	2nd telephone number associated with input Z-2	20 digits	[PR] [6] [#] [Num] [#]**	None	
7	3rd telephone number associated with input Z-2	20 digits	[PR] [7] [#] [Num] [#]**	None	
8	4th telephone number associated with input Z-2	20 digits	[PR] [8] [#] [Num] [#]**	None	
9	Inaccessible to installers or users	-			
10	Inhibit or permit the listen-in function: 0 - inhibited; 1 - permitted	0 or 1	[PR] [10] [#] [Code] [#]	1	
11	Select Dialing method: 0 - DTMF; 1 - Pulse	0 or 1	[PR] [11] [#] [Code] [#]	0	
12	No. of dialing attempts for alarms at input Z-1	1 - 15*	[PR] [12] [#] [Num] [#]	4	
13	No. of dialing attempts for alarms at input Z-2	1 - 15*	[PR] [13] [#] [Num] [#]	4	
14	Delay (in seconds) between trigger and action (to permit the user to clear a false alarm)	1 - 255*	[PR] [14] [#] [Sec] [#]	3	
15	Order of transmission of message segments: 0 - alarm type segment first; 1 - identification segment first	0 or 1	[PR] [15] [#] [Code] [#]	1	
16	LF output logic: 0 - N.C.; 1 - N.O.	0 or 1	[PR] [16] [#] [Num] [#]	1	
17-19	Inaccessible to installers or users	-			
20	Number of recorded message repeats	1 - 255*	[PR] [20] [#] [Num] [#]	4	
21	Listen-in duration (in seconds)	1 - 255*	[PR] [21] [#] [Sec] [#]	60	
22	Z-1 input definition (Z-1 logic): 0 - N.O.; 1 - N.C.	0 or 1	[PR] [22] [#] [Code] [#]	0	
23	Z-2 input definition (Z-2 logic): 0 - N.O.; 1 - N.C.	0 or 1	[PR] [23] [#] [Code] [#]	0	
24	Selection of Backup or Non-backup reporting method: 0 - non-backup; 1 - backup (see note)	0 or 1	[PR] [24] [#] [Code] [#]	1	

* The "00" value is illegal in this memory location

** When programming a 20-digit number, the LED will go off by itself after the 20th digit and the number will be saved.

Notes:

- In the Backup reporting mode, receiving an acknowledge signal from a single telephone in a group of 4 is sufficient to consider the current event closed and call off the communication session. The remaining 3 telephones are there for backup purposes only.
In the Non-Backup mode, an acknowledge signal must be received from each telephone in the group of 4 before the current event is considered reported and closed.
- If the dialer is calling a cellular phone, the number of repeats should be set between 10 and 20 to compensate for latency in the cellular network.

6. TEST

After installation, programming, and message recording, correct function should be verified.

Testing can be made easier if you possess a cellular telephone and a portable AM/FM radio. For testing purposes, you can temporarily program your cellular telephone's number in Location 1 (the first telephone in the first group) and in Location 5 (the first telephone in the second group). This way you can monitor both messages and exercise remote control without bothering anyone. Switch the AM/FM radio on to play softly and put it about 2m (6 ft) away from the dialer. Then proceed as follows:

- A. Trigger input Z-1 by opening or closing the circuit, as necessary.
- B. If a predialing pause has not been programmed, the DIAL LED will immediately light. It will remain lighted (tone dialing) or flash (pulse dialing) indicating that the dialer has indeed begun its dialing routine.
- C. If all goes well, your cellular telephone will ring. Answer the call and listen. The message should come through loud and clear. Verify that the message segments are read in the correct order, as programmed (identification segment first or alarm type segment first).
- D. Wait for the 3-second interval between message repetitions and press the "1" key on your telephone. After that, the message should not be repeated any more.
- E. If the listening-in function is permitted, you should now start hearing the radio through the telephone's earpiece.

Note: To prevent acoustic feedback, move into another room and continue monitoring from there.

- F. Watch for the warning beep that sounds shortly before end of session. Press the "1" key on your telephone and verify that the listen-in period carries on instead of coming to an abrupt end.
- G. Press the telephone's "9" key twice in succession. The dialer should terminate the communication session and go "on hook". If the dialer is in the non-backup mode ("0" has been selected Location 24), press the **STOP** button ["DL-125C"] or disconnect the power ("DL-125CA") to prevent further dialing.
- H. Reconnect the power (DL-125CA only) and trigger input Z-2 by opening or closing the circuit, as necessary.
- I. Repeat steps B through G above for this input too. If all goes well, reprogram the telephone numbers in Locations 1 and 5 as requested by the user.

Notes:

1. Testing can be carried out without a cellular telephone, provided that you secure cooperation of the called parties. You must warn them in advance that you are about to test the system, explain briefly what they have to do and have them report to you later whether all went well.
2. It is recommended to use a telephone line test set as an aid to troubleshooting connection issues.

7. SPECIAL NOTES

FCC Requirements

1. The Federal Communications Commission (FCC) has established Rules which permit this device to be directly connected to the telephone network. Standardized jacks are used for these connections. This equipment should not be used on party lines or coin lines.
2. If this device is malfunctioning, it may be causing also harm to the telephone network; this device should be disconnected until the source of the problem can be determined, and until repair has been made. If this is not done, the telephone company may temporarily disconnect service.
3. The telephone company may make changes in its technical operations and procedures; if such changes affect the compatibility or use of this

device, the telephone company is required to give adequate notice of the changes.

4. If the telephone company requests information on what equipment is connected to their lines, inform them of:
 - (a) The telephone number that this unit is connected to,
 - (b) The ringer equivalence number (0.0B)
 - (c) The USOC jack required (RJ-31X), and
 - (d) The FCC registration number







Items (b) and (d) are indicated on the label. The ringer equivalence number (REN) is used to determine how many devices can be connected to your telephone line. In most areas, the sum of the RENs of all devices on any one line should not exceed five (5.0). If too many devices are attached, they may not ring properly.

APPENDIX A. USER INFORMATION



A.1 User Guidance



We recommend to photo-copy this section for all the dialer users - the proprietor of the protected premises and all called parties.

If programmed correctly, the dialer will operate automatically without user's intervention. However, the user can initiate an alarm or stop operation manually.

-   Pressing AL-1 will cause the dialer to call the first group of phone numbers and send them the relevant verbal message.
-   Pressing AL-2 will cause the dialer to call the second group of phone numbers and send them the relevant verbal message.
-   Pressing STOP (DL-125C only) will cause the dialer to stop communicating, disengage the line and check both inputs. If an input is "in alarm", a new communication session will start. If both inputs are "normal", the dialer will standby. Note: This function is disabled in the DL-125CA.

While listening to the incoming verbal message, the called party can exercise some control over the dialer by sending DTMF (touchtone) codes over the telephone line:

-   Serves as an acknowledgement. The dialer will stop sending the message and will permit "listening in". Before the listen-in period ends, the dialer beeps once. Pressing [1] again will start another listen-in period.

-   Serves as an acknowledgement and causes the dialer to stop sending the message and go "on hook". The dialer will then call the remaining numbers (if programmed to do so).

A.2 Data Record

AL-1 DATA

Message

.....

1st called party

2nd called party

3rd called party

4th called party

AL-2 DATA

Message

.....

1st called party

2nd called party

3rd called party

4th called party

WARRANTY

Visonic Limited (the "Manufacturer") warrants this product only (the "Product") to the original purchaser only (the "Purchaser") against defective workmanship and materials under normal use of the Product for a period of twelve (12) months from the date of shipment by the Manufacturer.

This Warranty is absolutely conditional upon the Product having been properly installed, maintained and operated under conditions of normal use in accordance with the Manufacturers recommended installation and operation instructions. Products which have become defective for any other reason, according to the Manufacturers discretion, such as improper installation, failure to follow recommended installation and operational instructions, neglect, willful damage, misuse or vandalism, accidental damage, alteration or tampering, or repair by anyone other than the manufacturer, are not covered by this Warranty.

The Manufacturer does not represent that this Product may not be compromised and/or circumvented or that the Product will prevent any death and/or personal injury and/or damage to property resulting from burglary, robbery, fire or otherwise, or that the Product will in all cases provide adequate warning or protection. The Product, properly installed and maintained, only reduces the risk of such events without warning and it is not a guarantee or insurance that such events will not occur.

THIS WARRANTY IS EXCLUSIVE AND EXPRESSLY IN LIEU OF ALL OTHER WARRANTIES, OBLIGATIONS OR LIABILITIES, WHETHER WRITTEN, ORAL, EXPRESS OR IMPLIED, INCLUDING ANY WARRANTY OF MERCHANTABILITY OR FITNESS FOR A PARTICULAR PURPOSE, OR OTHERWISE. IN NO CASE SHALL THE MANUFACTURER BE LIABLE TO ANYONE FOR ANY CONSEQUENTIAL OR INCIDENTAL DAMAGES FOR BREACH OF THIS WARRANTY OR ANY OTHER WARRANTIES WHATSOEVER, AS AFORESAID.

THE MANUFACTURER SHALL IN NO EVENT BE LIABLE FOR ANY SPECIAL, INDIRECT, INCIDENTAL, CONSEQUENTIAL OR PUNITIVE DAMAGES OR FOR LOSS, DAMAGE, OR EXPENSE, INCLUDING LOSS OF USE, PROFITS, REVENUE, OR GOODWILL, DIRECTLY OR INDIRECTLY ARISING FROM PURCHASER'S USE OR INABILITY TO USE THE PRODUCT, OR FOR LOSS OR DESTRUCTION OF OTHER PROPERTY OR FROM ANY OTHER CAUSE, EVEN IF MANUFACTURER HAS BEEN ADVISED OF THE POSSIBILITY OF SUCH DAMAGE.

THE MANUFACTURER SHALL HAVE NO LIABILITY FOR ANY DEATH, PERSONAL AND/OR BODILY INJURY AND/OR DAMAGE TO PROPERTY OR OTHER LOSS WHETHER DIRECT, INDIRECT, INCIDENTAL, CONSEQUENTIAL OR OTHERWISE, BASED ON A CLAIM THAT THE PRODUCT FAILED TO FUNCTION.

However, if the Manufacturer is held liable, whether directly or indirectly, for any loss or damage arising under this limited warranty, **THE MANUFACTURER'S MAXIMUM LIABILITY (IF ANY) SHALL NOT IN ANY CASE EXCEED THE PURCHASE PRICE OF THE PRODUCT**, which shall be fixed as liquidated damages and not as a penalty, and shall be the complete and exclusive remedy against the Manufacturer.

When accepting the delivery of the Product, the Purchaser agrees to the said conditions of sale and warranty and he recognizes having been informed of.

Some jurisdictions do not allow the exclusion or limitation of incidental or consequential damages, so these limitations may not apply under certain circumstances.

The Manufacturer shall be under no liability whatsoever arising out of the corruption and/or malfunctioning of any telecommunication or electronic equipment or any programs.

The Manufacturers obligations under this Warranty are limited solely to repair and/or replace at the Manufacturer's discretion any Product or part thereof that may prove defective. Any repair and/or replacement shall not extend the original Warranty period. The Manufacturer shall not be responsible for dismantling and/or reinstallation costs. To exercise this Warranty the Product must be returned to the Manufacturer freight pre-paid and insured. All freight and insurance costs are the responsibility of the Purchaser and are not included in this Warranty.

This warranty shall not be modified, varied or extended, and the Manufacturer does not authorize any person to act on its behalf in the modification, variation or extension of this warranty. This warranty shall apply to the Product only. All products, accessories or attachments of others used in conjunction with the Product, including batteries, shall be covered solely by their own warranty, if any. The Manufacturer shall not be liable for any damage or loss whatsoever, whether directly, indirectly, incidentally, consequentially or otherwise, caused by the malfunction of the Product due to products, accessories, or attachments of others, including batteries, used in conjunction with the Products. This Warranty is exclusive to the original Purchaser and is not assignable.

This Warranty is in addition to and does not affect your legal rights. Any provision in this warranty which is contrary to the Law in the state or country where the Product is supplied shall not apply.

Warning: The user must follow the Manufacturer's installation and operational instructions including testing the Product and its whole system at least once a week and to take all necessary precautions for his/her safety and the protection of his/her property.

1/08



W.E.E.E. Product Recycling Declaration

For information regarding the recycling of this product you must contact the company from which you originally purchased it. If you are discarding this product and not returning it for repair then you must ensure that it is returned as identified by your supplier. **This product is not to be thrown away with everyday waste.**

Directive 2002/96/EC Waste Electrical and Electronic Equipment.



EMAIL: info@visonic.com

INTERNET: www.visonic.com

©VISONIC LTD. 2015 DL-125C, DL-125CA DE5817- (REV. 5, 11/15)



DE5817-

